



# Gas Furnaces 95AF2V

## PRODUCT SPECIFICATIONS

### INSTALLATION OPTIONS

- Upflow/Horizontal models

### HEAT EXCHANGER

- Aluminized steel primary heat exchanger with crimped non-welded construction
- Stainless steel secondary heat exchanger
- Flue condensate trap furnished

### BURNERS

- Aluminized steel inshot burners for smooth combustion
- Isolated burner enclosure for quiet operation

### CABINET CONSTRUCTION

- Unitized construction for cabinet integrity
- Bottom or side return air
- Baked on pre-painted steel cabinet finish
- Left or right side gas and electric entry
- Heat exchanger compartment is insulated to increase efficiency and reduce sound levels

### BLOWER

- Efficient ECM variable speed blower motor
- Blower motor features “soft start” and “soft stop” for quiet operation
- Active and passive dehumidification feature
- Dynamically balanced blower wheel with resilient motor mounts for smooth and quiet operation
- Easily removable slide-out blower design

### CONTROLS

- Two-stage gas valve
- Integrated ignition and fan control features self-diagnostic capability
- Hot surface ignitor
- Color-coded control wiring
- Compatible with single or two-stage thermostats for heating

### VENTING

- One or two-pipe venting ready

**95% AFUE**  
**Two-Stage Heat**  
**Variable Speed Blower**  
**29,000 to 110,000 Btuh Input**  
**3 to 5 Tons Add-On Cooling**

NOTE - AVAILABLE IN CANADA ONLY!



Upflow /  
Horizontal



Proper sizing and installation of equipment is critical to achieve optimal performance. Ask your contractor for details or visit <http://www.nrcan.gc.ca>

### Warranty

Heat Exchanger - 20 Year Limited  
Parts - 5 Year Limited

# Gas Furnaces

## 95AF2V

### Model Number Identification

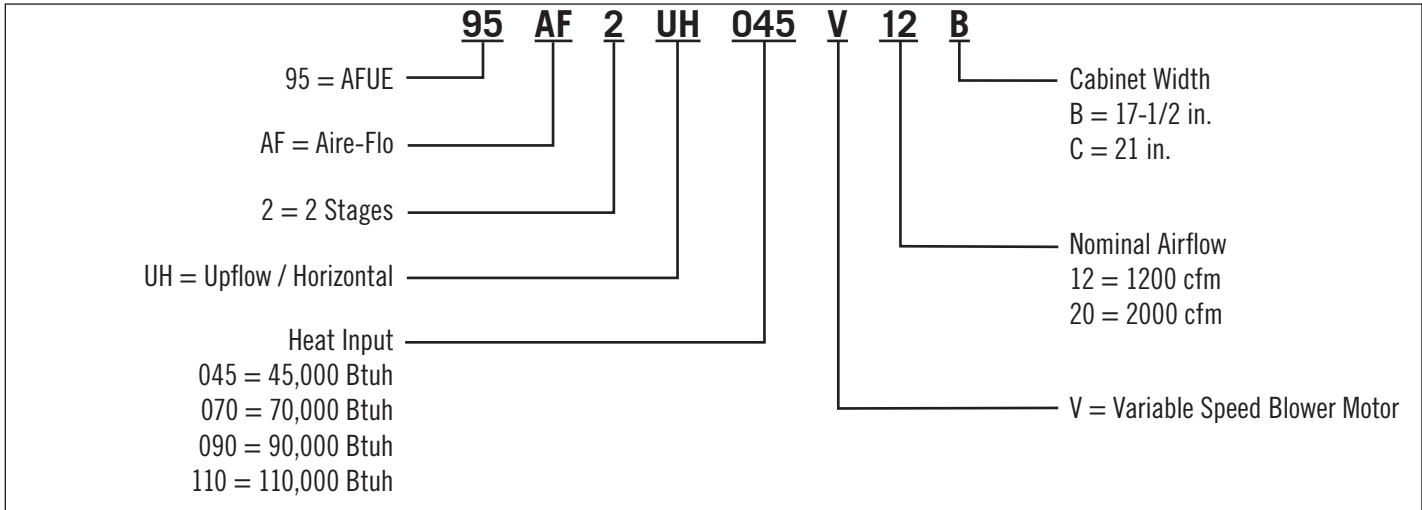

### Specifications

Model No.	95AF2UH045V12B		95AF2UH070V12B		95AF2UH090V12C		95AF2UH110V20C	
	1st Stage	2nd Stage	1st Stage	2nd Stage	1st Stage	2nd Stage	1st Stage	2nd Stage
Input Btuh	29,000	44,000	43,000	66,000	57,000	88,000	72,000	110,000
Output Btuh	28,000	42,000	41,000	62,000	55,000	84,000	70,000	105,000
AFUE (Isolated Comb. System)	95.0%		95.0%		95.0%		95.0%	
Temperature Rise (°F)	High	35 – 65	50 – 80	60 – 90	45 – 75	Low	20 – 50	25 – 55
Gas Pipe Size (in.)	1/2		1/2		1/2		1/2	
Inlet/Vent Connection in. (diameter)	2		2		2		2	
Condensate Drain Trap (PVC) - i.d.	3/4		3/4		3/4		3/4	
Volts/Hertz/Phase	120/60/1		120/60/1		120/60/1		120/60/1	
Blower Motor Horsepower	1/2		1/2		1/2		1	
Add-On Cooling (tons)	3		3		3		5	
Circuit Breaker or Fuse	15		15		15		20	
Full Load Amps	7.7		7.7		7.7		12.8	
Blower Wheel Size (Dia. x Width)	10 x 9		10 x 9		10 x 9		11 x 11	
Shipping Weight (lbs.)	130		138		154		174	

# Gas Furnaces

## 95AF2V

### Accessories

Model No.		95AF2UH045V12B 95AF2UH070V12B	95AF2UH090V12C 95AF2UH110V20C	
		Upflow / Horiz.	Upflow / Horiz.	
<b>CABINET</b>				
Horizontal Suspension Kit (Horizontal)		51W10	51W10	
Return Air Base (Upflow)		50W98	50W99	
<b>DRAIN KIT</b>				
Condensate Drain Heat Cable	6 ft.	26K68	26K68	
	24 ft.	26K69	26K69	
	50 ft.	26K70	26K70	
Heat Cable Tape	Fiberglass ½ in. x 66 ft.	36G53	36G53	
	Alum. Foil 2 in. x 60 ft.	16P89	16P89	
Crawlspace Vent Drain Kit		51W18	51W18	
<b>FILTER KITS</b>				
<sup>1</sup> Air Filter and Rack Kit (Upflow/Horizontal)	Horizontal (end)		87L96 (18 x 25 x 1)	87L97 (20 x 25 x 1)
	Side Return (Upflow)	Single	44J22	44J22
		10-pack	66K63	66K63
		Size	16 x 25 x 1	16 x 25 x 1
<b>GAS HEATING</b>				
High Altitude Pressure Switch Kit	4501-7500 ft.	93W81 (045) 93W80 (070)	93W82 (090) 93W80 (110)	
	7501-10,000 ft.	93W84 (045) 93W85 (070)	93W80 (090) 93W85 (110)	
Natural to LP Conversion Kit	0-7500 ft.	78W93	78W93	
LP to Natural Conversion Kit	0-7500 ft.	77W09	77W09	
Natural Gas High Altitude Orifice Kit	7501-10,000 ft.	73W37	73W37	
LP High Altitude Orifice Kit	7501-10,000 ft.	78W96	78W96	
<b>NIGHT SERVICE KIT</b>				
Night Service Kit		84W50	84W50	
<b>VENTING</b>				
Concentric Vent Kit	1-1/2 in. (US)	71M80	71M80	
	2 in. (US)	69M29	69M29	
	3 in. (US)	---	60L46	
	2 in. (Canada)	44W92	44W92	
	3 in. (Canada)	---	44W93	
Flush Mount	2, 2-1/2 or 3 in. (US)	51W11	51W11	
	2, 2-1/2 or 3 in. (Canada)	51W12	51W12	
Wall - Close Couple	2 in. (US)	22G44	---	
	3 in. (US)	44J40	44J40	
Wall - Close Couple WTK	2 in. (Canada)	30G28	---	
	3 in. (Canada)	81J20	81J20	
Roof	2 in.	15F75	15F75	
Wall Ring Kit	2 in.	15F74	<sup>3</sup> 15F74	
<sup>2</sup> Flashing Kit	2 in.	44J41	44J41	

<sup>1</sup> Cleanable polyurethane frame type filter.

<sup>2</sup> Kits contain enough parts for two, non-direct vent installations.

<sup>3</sup> Non-direct vent only.

NOTE - Termination Kits 44W92, 44W93, 30G28, 51W12, 81J20 are certified to ULC S636 standard for use in Canada only.

# Gas Furnaces 95AF2V

## High Altitude Derate

NOTE - Units may be installed at altitudes up to 10,000 ft.

At altitudes above 4501 ft. the unit must be derated to match the manifold pressure information shown below.

Units installed at altitudes of 4501 to 10,000 ft. require a pressure switch change.

Units installed at altitudes of 7501 to 10,000 ft. require an orifice change.

See the Gas Heat Accessories table for ordering information.

NOTE - This is the only permissible derate for these units.

NOTE - In Canada, certification for installations at elevations over 4500 feet is the jurisdiction of local authorities.

Input	Gas	Manifold Pressure in. w.g.										Supply Line Pressure in. w.g. 0 - 10,000 ft.	
		0 - 4500 ft.		4501 - 5500 ft.		5501 - 6500 ft.		6501 - 7500 ft.		7501 - 10,000 ft.		Min.	Max.
		Low Fire	High Fire	Low Fire	High Fire	Low Fire	High Fire	Low Fire	High Fire	Low Fire	High Fire		
All Sizes	Natural	1.7	3.5	1.6	3.3	1.5	3.2	1.5	3.1	1.7	3.5	4.5	13.0
	LPG/Propane	4.9	10.0	4.6	9.4	4.4	9.1	4.3	8.9	4.9	10.0	11.0	13.0

## Clearance to Combustibles (in.)

Sides	<sup>1</sup> 0
Rear	0
Top/Plenum	<sup>1</sup> 1
Front	0
Front (service/alcove)	24
Floor	<sup>2</sup> Combustible

NOTE – Air for combustion must conform to the methods outlined in the National Fuel Gas Code (NFPA 54/ANSI-Z223.1) or the National Standard of Canada CAN/CSA-B149.1 Natural Gas and Propane Installation Code”.

NOTE – In the U.S. flue sizing must conform to the methods outlined in the current National Fuel Gas Code (NFPA 54/ANSI-Z223.1) or applicable provisions of local building codes. In Canada flue sizing must conform to the methods outlined in National Standard of Canada CAN/CSA-B149.1.

<sup>1</sup> Allow proper clearances to accommodate condensate trap and vent pipe installation.

<sup>2</sup> Do not install the upflow furnace directly on carpeting, tile, or other combustible materials other than wood flooring.

# Gas Furnaces

## 95AF2V

### Blower Performance Data

Model No.	Stage	Speed Adjustment Jumper Setting	Heating CFM @ .10" – .80" w.c.				Cooling CFM @ .10" – .80" w.c.			
			Jumper Setting				Jumper Setting			
			"D"	"C"	"B"	"A"	"D"	"C"	"B"	"A"
95AF2UH045V12B	2nd Stage	+	745	875	990	1005	905	1075	1210	1370
		Norm	685	765	895	910	815	980	1120	1255
		–	610	695	785	810	720	885	1020	1135
	1st Stage	+	685	765	895	910	595	760	865	980
		Norm	620	705	800	820	540	660	785	890
		–	545	625	715	725	485	600	695	790
95AF2UH070V12B	2nd Stage	+	965	1130	1255	1400	860	1060	1215	1365
		Norm	880	990	1140	1295	810	960	1130	1265
		–	810	890	1030	1170	705	840	1005	1140
	1st Stage	+	940	1070	1195	1345	600	740	840	970
		Norm	830	965	1100	1235	555	665	770	855
		–	755	840	975	1130	500	600	680	790
95AF2UH090V12C	2nd Stage	+	1060	1135	1240	1430	875	1040	1210	1360
		Norm	960	1040	1120	1310	800	945	1100	1245
		–	830	935	980	1175	720	840	970	1115
	1st Stage	+	960	1040	1120	1310	625	710	830	950
		Norm	875	945	995	1195	565	670	760	860
		–	790	840	920	1080	520	610	685	785
95AF2UH110V20C	2nd Stage	+	1560	1760	1905	2080	1310	1560	1745	1955
		Norm	1415	1610	1740	1930	1220	1405	1570	1795
		–	1285	1485	1560	1745	1075	1270	1430	1635
	1st Stage	+	1155	1325	1420	1565	935	1065	1245	1405
		Norm	1055	1200	1310	1480	865	970	1145	1280
		–	935	1075	1170	1315	790	890	1025	1165
95AF2UH135V20D	2nd Stage	+	1650	1845	2000	2195	1395	1640	1840	2055
		Norm	1495	1660	1880	1985	1290	1480	1660	1905
		–	1360	1500	1670	1850	1170	1330	1500	1705
	1st Stage	+	1300	1435	1630	1715	1015	1160	1330	1480
		Norm	1190	1325	1465	1620	940	1085	1200	1345
		–	1095	1190	1340	1430	870	965	1110	1225

# Gas Furnaces 95AF2V

## Vent Lengths - Feet

NOTE - Size intake and exhaust pipe length separately. Values in table are for Intake OR Exhaust, not combined total. Both Intake and Exhaust must be same pipe size.

STANDARD TERMINATION AT ELEVATION 0 - 4500 ft.																
Pipe Size		2 in.					2-1/2 in.					3 in.				
Input		045	070	090	110	135	045	070	090	110	135	045	070	090	110	135
No. of 90° elbows used	1	76	61	39	19	N/A	110	110	88	53	N/A	133	132	113	113	109
	2	71	56	34	14	N/A	105	105	83	48	N/A	128	127	108	108	104
	3	66	51	29	9	N/A	100	100	78	43	N/A	123	122	103	103	99
	4	61	46	24	N/A	N/A	95	95	73	38	N/A	118	117	98	98	94
	5	56	41	19	N/A	N/A	90	90	68	33	N/A	113	112	93	93	89
	6	51	36	14	N/A	N/A	85	85	63	28	N/A	108	107	88	88	84
	7	46	31	9	N/A	N/A	80	80	58	23	N/A	103	102	83	83	79
	8	41	26	N/A	N/A	N/A	75	75	53	18	N/A	98	97	78	78	74
	9	36	21	N/A	N/A	N/A	70	70	48	13	N/A	93	92	73	73	69
	10	31	16	N/A	N/A	N/A	65	65	43	8	N/A	88	87	68	68	64
STANDARD TERMINATION AT ELEVATION 4501 - 10,000 ft.																
Pipe Size		2 in.					2-1/2 in.					3 in.				
Input		045	070	090	110	135	045	070	090	110	135	045	070	090	110	135
No. of 90° elbows used	1	76	61	39	N/A	N/A	110	110	88	53	N/A	133	132	113	113	109
	2	71	56	34	N/A	N/A	105	105	83	48	N/A	128	127	108	108	104
	3	66	51	29	N/A	N/A	100	100	78	43	N/A	123	122	103	103	99
	4	61	46	24	N/A	N/A	95	95	73	38	N/A	118	117	98	98	94
	5	56	41	19	N/A	N/A	90	90	68	33	N/A	113	112	93	93	89
	6	51	36	14	N/A	N/A	85	85	63	28	N/A	108	107	88	88	84
	7	46	31	9	N/A	N/A	80	80	58	23	N/A	103	102	83	83	79
	8	41	26	N/A	N/A	N/A	75	75	53	18	N/A	98	97	78	78	74
	9	36	21	N/A	N/A	N/A	70	70	48	13	N/A	93	92	73	73	69
	10	31	16	N/A	N/A	N/A	65	65	43	8	N/A	88	87	68	68	64
CONCENTRIC TERMINATION ELEVATION 0 - 4500 ft.																
Pipe Size		2 in.					2-1/2 in.					3 in.				
Input		045	070	090	110	135	045	070	090	110	135	045	070	090	110	135
No. of 90° elbows used	1	68	53	37	17	N/A	100	100	84	49	N/A	116	116	109	109	100
	2	63	48	32	12	N/A	95	95	79	44	N/A	111	111	104	104	95
	3	58	43	27	7	N/A	90	90	74	39	N/A	106	106	99	99	90
	4	53	38	22	N/A	N/A	85	85	69	34	N/A	101	101	94	94	85
	5	48	33	17	N/A	N/A	80	80	64	29	N/A	96	96	89	89	80
	6	43	28	12	N/A	N/A	75	75	59	24	N/A	91	91	84	84	75
	7	38	23	12	N/A	N/A	70	70	54	19	N/A	86	86	79	79	70
	8	33	18	N/A	N/A	N/A	65	65	49	14	N/A	81	81	74	74	65
	9	28	13	N/A	N/A	N/A	60	60	44	9	N/A	76	76	69	69	60
	10	23	8	N/A	N/A	N/A	55	55	39	N/A	N/A	71	71	64	64	55
CONCENTRIC TERMINATION ELEVATION 4500 - 10,000 ft.																
Pipe Size		2 in.					2-1/2 in.					3 in.				
Input		045	070	090	110	135	045	070	090	110	135	045	070	090	110	135
No. of 90° elbows used	1	68	53	37	N/A	N/A	100	100	84	49	N/A	116	116	109	109	100
	2	63	48	32	N/A	N/A	95	95	79	44	N/A	111	111	104	104	95
	3	58	43	27	N/A	N/A	90	90	74	39	N/A	106	106	99	99	90
	4	53	38	22	N/A	N/A	85	85	69	34	N/A	101	101	94	94	85
	5	48	33	17	N/A	N/A	80	80	64	29	N/A	96	96	89	89	80
	6	43	28	12	N/A	N/A	75	75	59	24	N/A	91	91	84	84	75
	7	38	23	7	N/A	N/A	70	70	54	19	N/A	86	86	79	79	70
	8	33	18	N/A	N/A	N/A	65	65	49	14	N/A	81	81	74	74	65
	9	28	13	N/A	N/A	N/A	60	60	44	9	N/A	76	76	69	69	60
	10	23	8	N/A	N/A	N/A	55	55	39	N/A	N/A	71	71	64	64	55

# Gas Furnaces 95AF2V

## Vent Lengths (Exhaust)

Ventilated Attic Or Crawlspace Intake Air - Feet

STANDARD TERMINATION AT ELEVATION 0 - 4500 ft.																
Pipe Size		2 in.					2-1/2 in.					3 in.				
Input		045	070	090	110	135	045	070	090	110	135	045	070	090	110	135
No. of 90° elbows used	1	66	51	29	9	N/A	95	95	73	38	N/A	113	113	93	93	89
	2	61	46	24	4	N/A	90	90	68	33	N/A	108	108	88	88	84
	3	56	41	19	N/A	N/A	85	85	63	28	N/A	103	103	83	83	79
	4	51	36	14	N/A	N/A	80	80	58	23	N/A	98	98	78	78	74
	5	46	31	9	N/A	N/A	75	75	53	18	N/A	93	93	73	73	69
	6	41	26	4	N/A	N/A	80	70	58	13	N/A	88	88	68	68	64
	7	36	21	N/A	N/A	N/A	65	65	43	8	N/A	83	83	63	63	59
	8	31	16	N/A	N/A	N/A	60	60	38	3	N/A	78	78	58	58	54
	9	26	11	N/A	N/A	N/A	55	55	33	N/A	N/A	73	73	53	53	49
	10	21	6	N/A	N/A	N/A	50	50	28	N/A	N/A	68	68	48	48	44
STANDARD TERMINATION ELEVATION 4501 - 10,000 ft.																
Pipe Size		2 in.					2-1/2 in.					3 in.				
Input		045	070	090	110	135	045	070	090	110	135	045	070	090	110	135
No. of 90° elbows used	1	66	51	29	N/A	N/A	95	95	73	38	N/A	113	112	93	93	89
	2	61	46	24	N/A	N/A	90	90	68	33	N/A	108	107	88	88	84
	3	56	41	19	N/A	N/A	85	85	63	28	N/A	103	102	83	83	79
	4	51	36	14	N/A	N/A	80	80	58	23	N/A	98	97	78	78	74
	5	46	31	9	N/A	N/A	75	75	53	18	N/A	93	92	73	73	69
	6	41	26	4	N/A	N/A	80	80	48	13	N/A	88	87	68	68	64
	7	36	21	N/A	N/A	N/A	65	65	43	8	N/A	83	82	63	63	59
	8	31	16	N/A	N/A	N/A	60	60	38	3	N/A	78	77	58	58	54
	9	26	11	N/A	N/A	N/A	55	55	33	N/A	N/A	73	72	53	53	49
	10	21	6	N/A	N/A	N/A	50	50	28	N/A	N/A	68	67	48	48	44

# Gas Furnaces 95AF2V

## Dimensions - inches (mm) Upflow

<sup>1</sup> NOTE - 20C and 20D size units that require air volumes over 1800 cfm must have one of the following:

1. Single side return air with transition, to accommodate 20 x 25 x 1 in. cleanable air filter. Required to maintain proper air velocity.
  2. Single side return air with Optional Return Air Base
  3. Bottom return air.
  4. Return air from both sides.
  5. Bottom and one side return air.
- See Blower Performance Tables for additional information.

<sup>2</sup> Optional Side Return Air Filter Kit is not for use with the Optional Return Air Base.

### Flue Condensate Trap Assembly

Furnished for external field installation on either side of unit. (See installation instructions for additional information.)

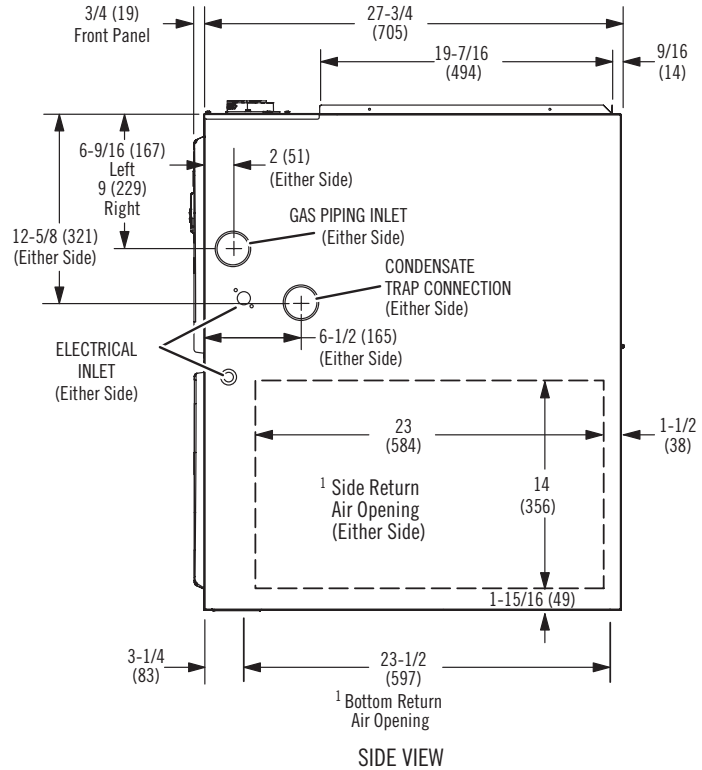
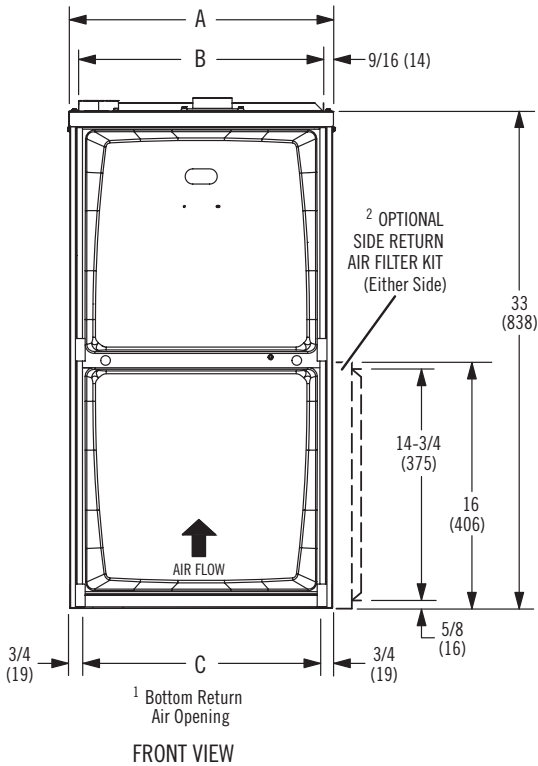
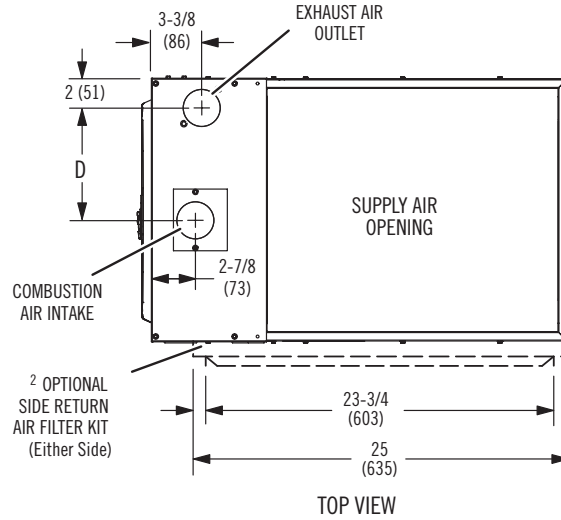
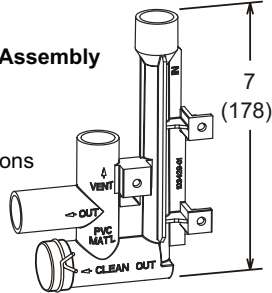

Model No.	A		B		C		D	
	in.	mm	in.	mm	in.	mm	in.	mm
95AF2UH045V12B 95AF2UH070V12B	17-1/2	446	16-3/8	416	16	406	7-5/8	194
95AF2UH090V12C 95AF2UH110V20C	21	533	19-7/8	505	19-1/2	495	9-3/8	238



# Gas Furnaces 95AF2V

## Dimensions - inches (mm) Horizontal

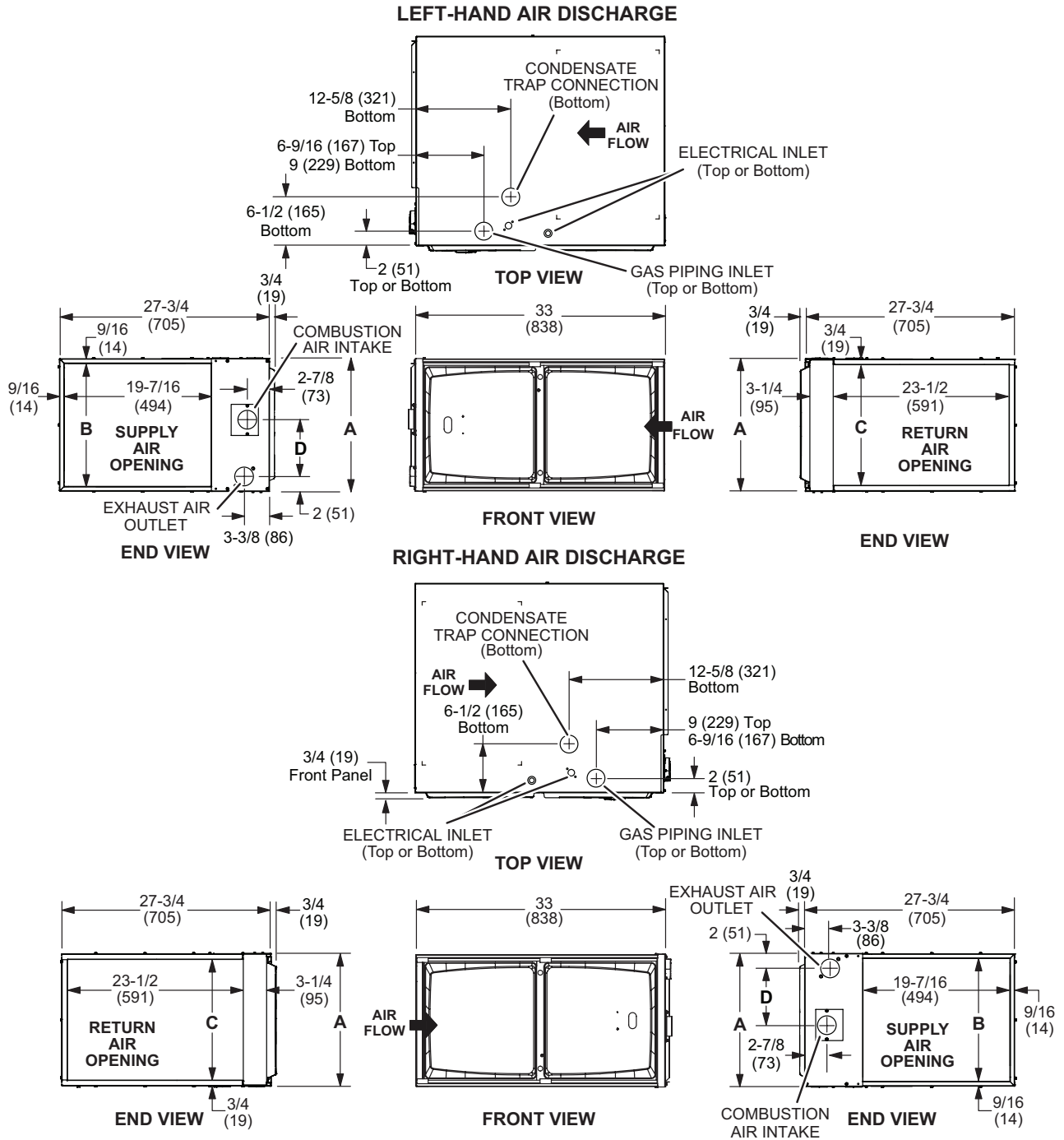

Model No.	A		B		C		D	
	in.	mm	in.	mm	in.	mm	in.	mm
95AF2UH045V12B 95AF2UH070V12B	17-1/2	446	16-3/8	416	16	406	7-5/8	194
95AF2UH090V12C 95AF2UH110V20C	21	533	19-7/8	505	19-1/2	495	9-3/8	238





# Gas Furnaces

## 95AF2V

### Revisions

Sections	Description of Change
Accessories/Gas Heating	Added High Altitude Derate information.
Document	Removed all downflow models (product discontinued). Removed 95AF2UH135V20D upflow/horizontal model (product discontinued). All other upflow/horizontal models are only available in Canada.



1.800.982.2333  
[www.aireflo-hvac.com](http://www.aireflo-hvac.com)

